



2015

FABRIQUÉ EN FRANCE



EDITO

Chers amis,

C'est avec fierté que nous vous convions à découvrir les formidables innovations TIME de cette année 2015.

- Les pédales tout d'abord, avec au sommet de notre gamme "route", la Xpresso 15, d'une légèreté extraordinaire (66,5 grammes) grâce à son roulement en céramique et à son corps carbone, et en "VTT", la XC4 et la XC2, 2 nouveaux modèles qui vont permettre de couvrir l'ensemble du marché du cross-country.
- Dans le domaine des cadres et du composite, 2015 sera également une année marquante. Parmi les nouveautés, le SKYLON, dont la modernité et les caractéristiques en termes de rigidité et de comportement raviront les coureurs et amateurs les plus exigeants.

Mais cette année, TIME va plus loin encore avec l'avènement de la fourche AKTIV qui révolutionne la technologie du vélo grâce à un mécanisme interne "actif" qui a pour effet de dissiper, remontant de la route, les fréquences les plus nuisibles à la performance du cycliste, son confort, sa tenue de route...

AKTIV est un dispositif breveté qui a nécessité plusieurs années de recherche et qui ouvre une nouvelle ère avec, pour la première fois, un dispositif filtrant l'ensemble des phénomènes vibratoires (au niveau du cintre, de la potence, mais également de la tige de selle), tout en préservant à 100% l'efficacité de pédalage. AKTIV, c'est un "toucher" de route inédit, de nouvelles sensations au service de la performance et d'un plaisir de rouler exceptionnel. Pour 2015, l'ensemble de nos modèles haut de gamme, SKYLON, IZON et FLUIDITY, seront équipés d'AKTIV.

Vive TIME, vive le MADE IN FRANCE !
Sincèrement,

Roland CATTIN

Dear friends,

It is with pride that we invite you to discover the great innovations at TIME in 2015.

- *The pedals firstly, with our top of the range "road" offering, the Xpresso 15. Ultralight (66.5 grams) with its ceramic bearing and carbon body. In the "MTB" category the XC4 and XC2, 2 new models that will allow us to cover the entire cross-country market.*
- *In the field of frames and composites, 2015 will be a landmark year for TIME with the all new SKYLON at the forefront of the range. It's cutting edge aesthetics, performance characteristics in terms of stiffness, aerodynamics and comfort will delight the most demanding of riders and amateurs.*

But this year, TIME goes further with the introduction of AKTIV fork technology that revolutionizes the bike with an "active" internal mechanism. AKTIV has the effect of dissipating, from the road, the frequencies most detrimental to cycling performance, comfort and road holding...

AKTIV is a patented device that has required several years of research and opens a new era, for the first time, a device that filters all vibration phenomena (at the handlebar, the stem and the seatpost) while maintaining 100% pedaling efficiency. AKTIV gives the road a new "feel", resulting in enhanced performance and an exceptionally pleasurable ride. For 2015, all of our top models, SKYLON, IZON and FLUIDITY, will be equipped with AKTIV.

*Long live the MADE IN FRANCE!
Sincerely,*

Roland CATTIN



FABRIQUÉ EN FRANCE

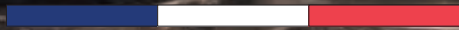

LA FILTRATION DES VIBRATIONS : UN SAVOIR-FAIRE TIME

REDUCING VIBRATIONS : A TIME SAVOIR FAIRE

AKTIV^{Hz}

RÉVOLUTIONNAIRE !

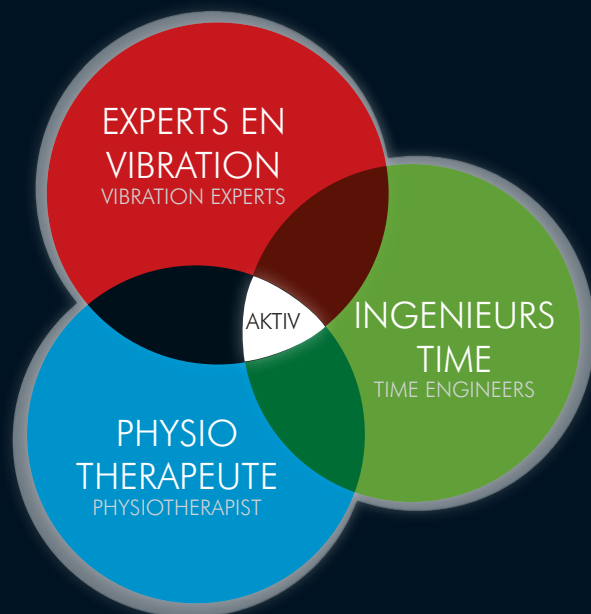

UNE ÉQUIPE SOUDÉE ET PLURIDISCIPLINAIRE
MOTIVÉE PAR LE BÉNÉFICE UTILISATEUR!

A COHESIVE AND MULTIDISCIPLINARY TEAM
MOTIVATED BY THE USER BENEFIT!

Les vibrations issues de la route sont à l'origine de nombreux micro traumatismes articulaires, détériorent le confort de roulage, la tenue de route, la maîtrise et le contrôle que l'on doit avoir de son vélo, nuisent à la sécurité et à la performance.

Dès ses premiers cadres, TIME s'est fixée comme priorité de traiter les phénomènes vibratoires sans jamais opposer confort et performance. La technologie RTM et le recours au VECTRAN, fibre polymère aux propriétés particulièrement amortissantes dont TIME s'est fait le précurseur, ont transcendé les qualités dynamiques des cadres TIME et forgé leur prestigieuse réputation.

Vibrations from the road are at the root of many micro-traumas to the joints, affecting ride comfort, road holding, command and control of the bike, compromising both safety and performance.

From its very first frames, TIME has made it a priority to treat vibration phenomena without compromising comfort and performance. RTM technology and the use of VECTRAN, a polymer fiber with exceptional damping characteristics, of which TIME became the forerunner, transcended the dynamic qualities of TIME frames and forged their prestigious reputation.

Aujourd'hui, après plusieurs années de recherche et le dépôt de 3 brevets, TIME va plus loin dans sa quête de performance et inaugure en première mondiale une fourche révolutionnaire, la fourche AKTIV, composée d'un batteur dynamique interne qui dissipe les pics de vibration néfastes au rendement et au confort du cycliste.

Today, TIME are going further in their quest for performance. Following several years of research and the application of three patents, TIME introduces AKTIV, a revolutionary fork featuring an integrated tuned mass damper, which dispels vibrations detrimental to the cyclist's performance and comfort.



De quoi s'agit-il ?

L'amplification vibratoire se produit lorsqu' un objet entre en résonance – quand il rencontre une fréquence vibratoire qui lui correspond – autour de 36 HZ pour un vélo TIME en utilisation. Cette fréquence appartient au domaine des amplitudes vibratoires perceptibles et défavorables au cycliste (entre 25 et 50Hz).

Le « batteur dynamique » est un système dissipatif qui, se mettant lui-même à vibrer, va prendre à son compte ces mauvaises vibrations et les annihiler. En traitant les vibrations au niveau de la fourche, au plus près de la route, on atténue l'ensemble des phénomènes vibratoires, ceux qui se ressentent au niveau de la tige de selle comme ceux qui se ressentent au niveau de la potence et du cintre.

How does it work ?

Low frequency vibrations between 25 and 50Hz can have the most detrimental effect on performance causing discomfort and fatigue. Vibrations experienced when cycling fall into this category.

The tuned mass damper is a dissipative system that is designed to stabilise against Harmonic Vibrations, these occur when the vibration of the bicycle and rider are in phase with the vibrations from the road. Through vibrating itself the Tuned Mass Damper absorbs the worst case vibrations by off-setting the vibrations phase – reducing their intensity.

Through many tests, TIME have discovered that the fork is the best place to treat harmonic vibrations - it is as close to the road as possible - reducing the effect of all vibration phenomena throughout the system (at the seat post, the pedals and the handle bars).

AVEC AKTIV, VOUS IREZ PLUS LOIN, PLUS LONGTEMPS, PLUS VITE !

WITH AKTIV, YOU WILL GO FARTHER, LONGER, FASTER ...

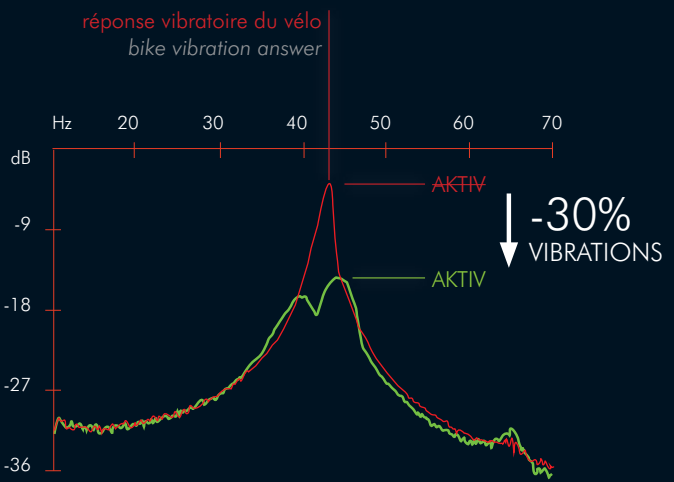

Contrairement à la plupart des systèmes existants dont le principe repose sur l'élasticité des matériaux (tige de selle, wishbone), AKTIV ne dégrade pas le rendement du vélo. Ce n'est pas un amortissement qui engendre souplesse et déperdition d'énergie, mais un dispositif actif qui préserve votre potentiel physique, améliore le comportement de votre vélo, et accroît votre efficacité de pédalage.

Unlike most existing systems that rely on material elasticity (seatpost, wishbone), AKTIV is not deteriorating the performance of the bike. This is not a shock absorption system which generates flexibility and energy loss, but an active device fully preserving the physical potential, improving the behavior of the bike and increasing the pedaling efficiency.

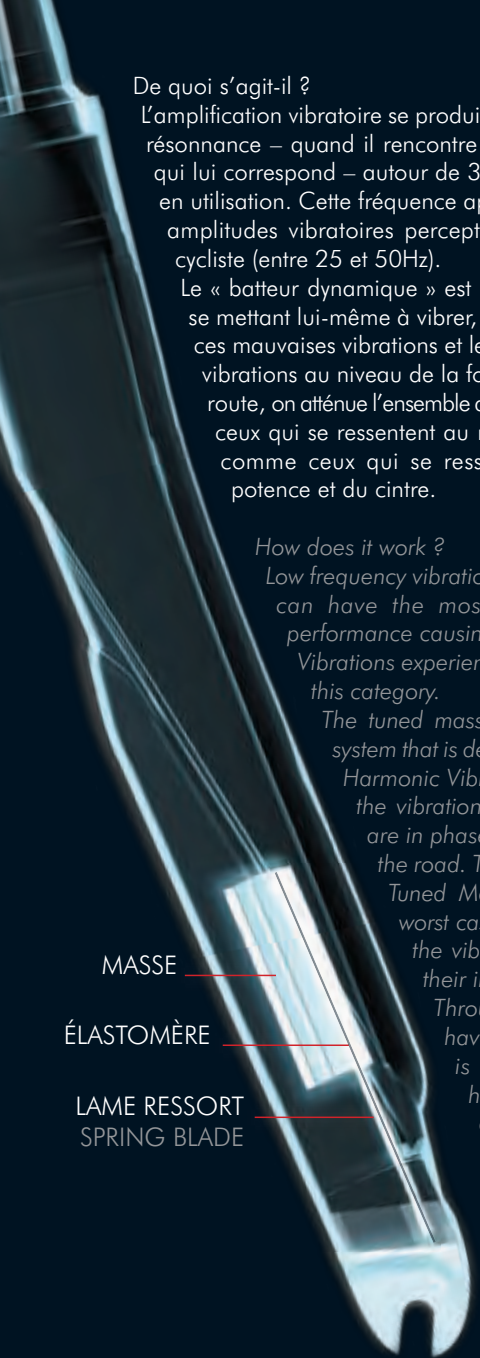

AERO

ALTITUDE

GAMME AKTIV



Skylon Aktiv Plasma



Skylon Aktiv Team



Skylon Aktiv Red



Skylon Aktiv White

p.12-13



Izon Aktiv White



Izon Aktiv Red

p.18-19

GAMME CLASSIQUE



Skylon Plasma



Skylon Team



Skylon Red



Skylon White

p.14-15



Izon Flamme Rouge



Izon Plasma

FABRIQUÉ EN FRANCE



ENDURANCE

VELODROME



Fluidity Aktiv Black



Fluidity Aktiv Yellow



Fluidity Aktiv Red

p.22-23



Fluidity Mont Rouge



Fluidity Mont Blanc

p.24-25



ZXRS Piste

p.26-27

FABRIQUÉ EN FRANCE

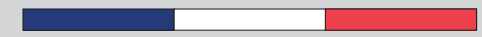

EXPLOSIVITY POWER PRECISION

SKYLON : Un cadre made in France dont l'explosivité et le fuselage aérodynamique constituent vos meilleurs alliés pour vous échapper et maintenir votre rythme face au vent.

SKYLON : Made in France Time weaving technic will provide the explosivity you need to breakaway and keep your rythm against the wind.

SKYLON

AÉRO



AERO

SIMULATION AÉRODYNAMIQUE
NUMÉRIQUE
AERODYNAMICS WITH CFD
COMPUTATIONAL FLUID DYNAMICS

+30%

RIGIDITÉ TORSIONNELLE
TORSIONAL RIGIDITY
VS ZX^{RS}

+45%

RIGIDITÉ À LA BOÎTE DE PÉDALIER
BOTTOM BRACKET RIGIDITY
VS ZX^{RS}

VERSATILE

COMPATIBLE TRANSMISSION
MÉCANIQUE ET ÉLECTRIQUE
ELECTRONIC & MECHANICAL
COMPATIBILITY

945_{g.}

SKYLON

FAÇONNÉ PAR L'AIR
SHAPED BY THE AIR



1.
Direction oversize et intégration de la fourche au cadre augmentent la rigidité torsionnelle et la précision de pilotage

Larger-section head tube and aerodynamic integrated fork design increase torsional rigidity and steering precision

2.
Boîtier de pédalier BB386 - augmentation des sections de tubes et rigidité accrue

BB386 bottom bracket - wider bearing spacing allows increased tubing cross-sections and improves rigidity



3.
Construction monobloc des bases asymétriques pour améliorer la transmission de puissance

Larger-section asymmetrical monobloc chainstays improve power transfer

4.
Tige de selle Direct Link plus légère et amélioration des réglages de position - Position de selle identique au ZXRS

Direct Link seatpost is lighter and allows increased front-to-rear adjustment. The seat tube angle as measured to the seat clamp is the same as the ZXRS

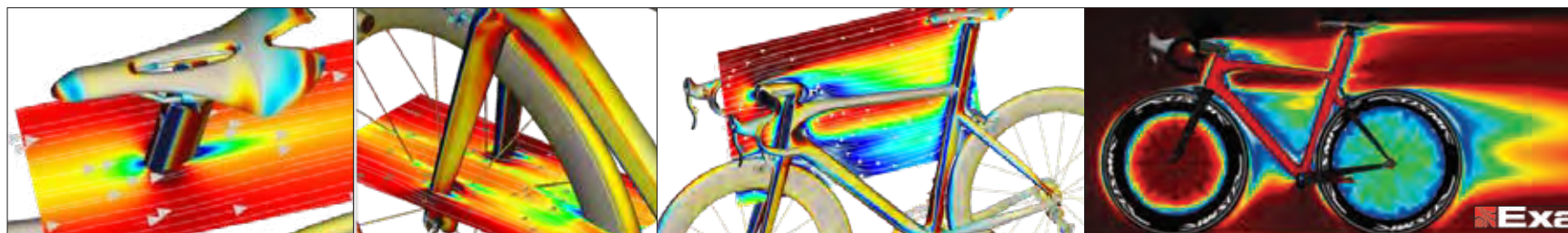

SKYLON AKTIV |
WHITE - MATT





SKYLON AKTIV |
TEAM - MATT



SKYLON AKTIV |
PLASMA - MATT



SKYLON AKTIV |
RED - GLOSS

SKYLON |
PLASMA - MATT





SKYLON
TEAM - MATT

SKYLON
WHITE - MATT

SKYLON
RED - GLOSS



IZON



REACTIVITY POLYVALENCE AGILITY

Izon est le vélo idéal pour les ascensions ou les critériums, vif et polyvalent il permet de bonnes relances et fait preuve d'agilité en descente.

Izon is the ideal all around bike, climbing or descending those long switchbacks to attacking around a corner in a criterium, the nervousness of the IZON will surprise you.



IZON AKTIV | *
WHITE - GLOSS



IZON AKTIV | *
RED - GLOSS



IZON
PLASMA - MATT | *
**



IZON
FLAMME ROUGE - GLOSS | *
**



Available in disk brake version / Disponibles en version disque**
Electronic & mechanical compatibility / Compatible transmission mécanique et électrique*

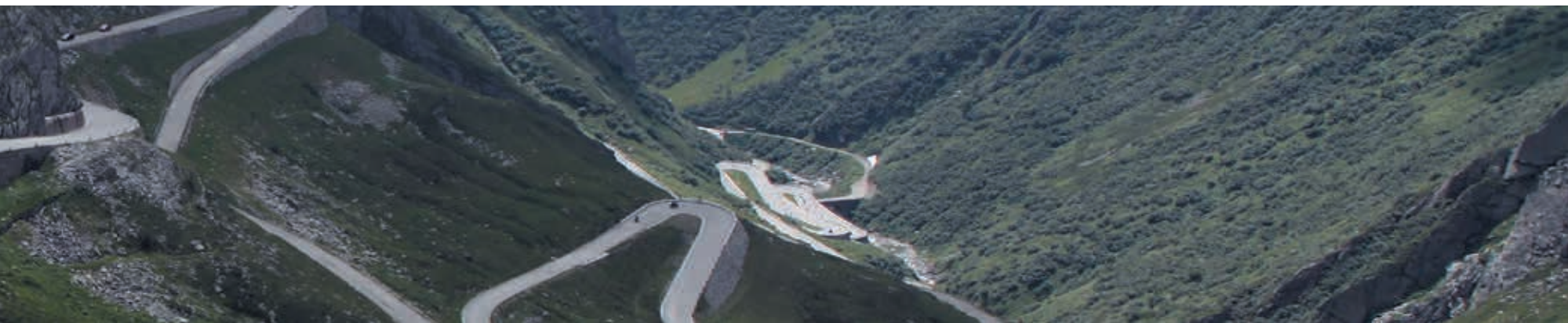

LONG DISTANCE FLUID RIDE PERFORMANCE

Gérard LEMOY
RUTA 40
5136 km
28 jours

Une géométrie et une construction idéale pour transformer vos longues sorties en partie de plaisir.

Geometry and ideal design to make your long trips fun.

Fluidity



FLUIDITY AKTIV | *
RED - GLOSS



FLUIDITY AKTIV | *
BLACK - MATT



*Compatible transmission mécanique et électrique / *Electronic & mechanical compatibility*

FLUIDITY AKTIV *
YELLOW - GLOSS





FLUIDITY | *
MONT ROUGE - GLOSS | **



* Compatible transmission mécanique et électrique / *Electronic & mechanical compatibility*

** Disponible en version disque / *Available in disk brake version*

FLUIDITY | *
MONT BLANC - GLOSS | **





« Courir les 6 jours les plus réputés avec le maillot de champion du monde sur le dos était un rêve, avec le ZXRS Piste il est devenu réalité. »

« Racing the most famous 6 days with the world champion jersey was a dream, with my ZXRS Piste it became reality. »

**Vivien Brisse,
Madison World
Champion 2013**

ZXRS PISTE
PLASMA - MATT

ZXRS
PISTE

LIGHT RIGIDITY RESPONSIVE

L'arme absolue pour décrocher la victoire sur un 6 jours ou un omnium.

Weapon of choice for victory on a 6 days race or an omnium.



LA GÉOMÉTRIE DES CADRES TIME 2015

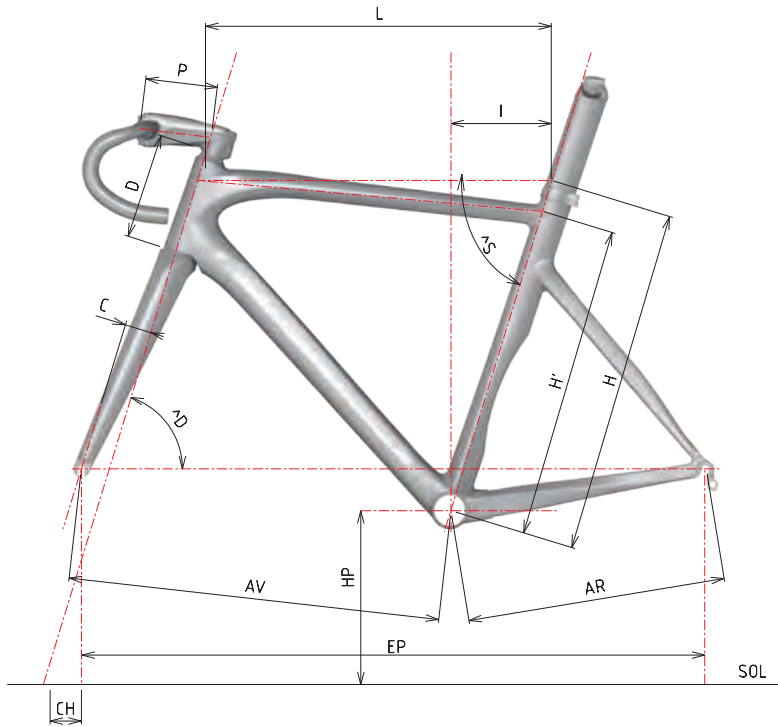

GLOSSAIRE / GLOSSARY

H : Hauteur axe - axe (valeur d'un cadre non sloping) / Virtual size: center to center if no sloping

H' : Hauteur Sloping (axe - axe) / Seat tube, center-to-center

L : Longueur / Top tube

I : Inclinaison du tube de selle / Set back

$\wedge S$: Angle du tube de selle / Seat tube angle

$\wedge D$: Angle de direction / Head tube angle

D : Hauteur de la douille de direction / Head tube height

C : Déport de la fourche / Fork rake

CH : Chasse / Trail

AV : Distance axe pédalier - axe roue avant / Bottom bracket center to front axle

AR : Distance axe pédalier - axe roue arrière / Bottom bracket center to rear axle

HP : Distance axe de pédalier - sol / Bottom bracket height

P : Taille de potence fournie dans le module / Stem length

EP : Distance axe de roue AV, axe de roue AR / Front axle to rear axle

SKYLON & SKYLON Aktiv - 6 tailles

Taille	H	H'	ΔSI	L	I	$\wedge S$	$\wedge D$	D	ΔD	C	CH	AV	AR	HP	EP
XXS	495	435	60	515	131	74,7°	71°	122	-	43	70	576	404	270	970
XS	510	450	60	530	143	73,7°	71,5°	133	-	43	68	578	404	270	973
S	530	480	50	540	155	73°	72°	149	-	43	64	578	404	270	973
M	550	500	50	555	161	73°	73°	166	-	43	58	584	404	270	979
L	570	530	40	570	167	73°	73°	186	-	43	58	599	404	270	994
XL	590	550	40	580	172	73°	73,5°	204	-	43	55	604	404	270	999

IZON & IZON Aktiv - 6 tailles

Taille	H	H'	ΔSI	L	I	$\wedge S$	$\wedge D$	D	ΔD	C	CH	AV	AR	HP	EP
XXS	495	435	60	515	131	74,7°	71°	122	-	43	70	576	402	270	963
XS	510	450	60	530	143	73,7°	71,5°	133	-	43	68	578	402	270	968
S	530	480	50	540	155	73°	72°	149	-	43	64	578	404	270	971
M	550	500	50	555	161	73°	73°	166	-	43	58	584	404	270	978
L	570	530	40	570	167	73°	73°	186	-	43	58	599	404	270	993
XL	590	550	40	580	172	73°	73,5°	204	-	43	55	604	404	270	998

FLUIDITY & FLUIDITY Aktiv - 7 tailles

Taille	H	H'	ΔSI	L	I	$\wedge S$	$\wedge D$	D	ΔD	C	CH	AV	AR	HP	EP
XXXS	470	420	50	505	118	75,5°	70,5°	123	26	43	74	575	402	270	965
XXS	495	435	60	515	131	74,7°	71°	147	25	43	70	576	402	270	968
XS	510	450	60	530	143	73,7°	71,5°	155	22	43	68	578	402	270	968
S	530	480	50	540	155	73°	72°	169	20	43	64	578	404	270	970
M	550	500	50	555	161	73°	73°	184	18	43	58	584	404	270	978
L	570	530	40	570	167	73°	73°	201	15	43	58	599	404	270	993
XL	590	550	40	580	172	73°	73,5°	219	15	43	55	604	404	270	999

ΔD = Supplément de douille de direction entre géométrie Racingdrive et géométrie Ergodrive

ZXRS piste - 6 tailles

Taille	H	H'	ΔSI	L	I	$\wedge S$	$\wedge D$	D	ΔD	C	CH	AV	AR	HP	EP
XXS	495	435	60	515	132	74,5°	71°	122	-	43	70	574	396 mini	277	-
XS	510	450	60	530	145	73,5°	71,5°	133	-	43	68	576	398 mini	277	-
S	530	480	50	540	155	73°	72°	149	-	43	64	578	400 mini	277	-
M	550	500	50	555	161	73°	73°	166	-	43	58	584	400 mini	277	-
L	570	530	40	570	167	73°	73°	186	-	43	58	599	400 mini	277	-
XL	590	550	40	580	172	73°	73,5°	204	-	43	55	604	400 mini	277	-



PEDALS





BIOPERFORMANCE

POUR TIME, PERFORMANCE ET BIOMÉCANIQUE SONT INDISSOCIABLES
FOR TIME, PERFORMANCE AND BIOMECHANICS ARE ONE AND THE SAME

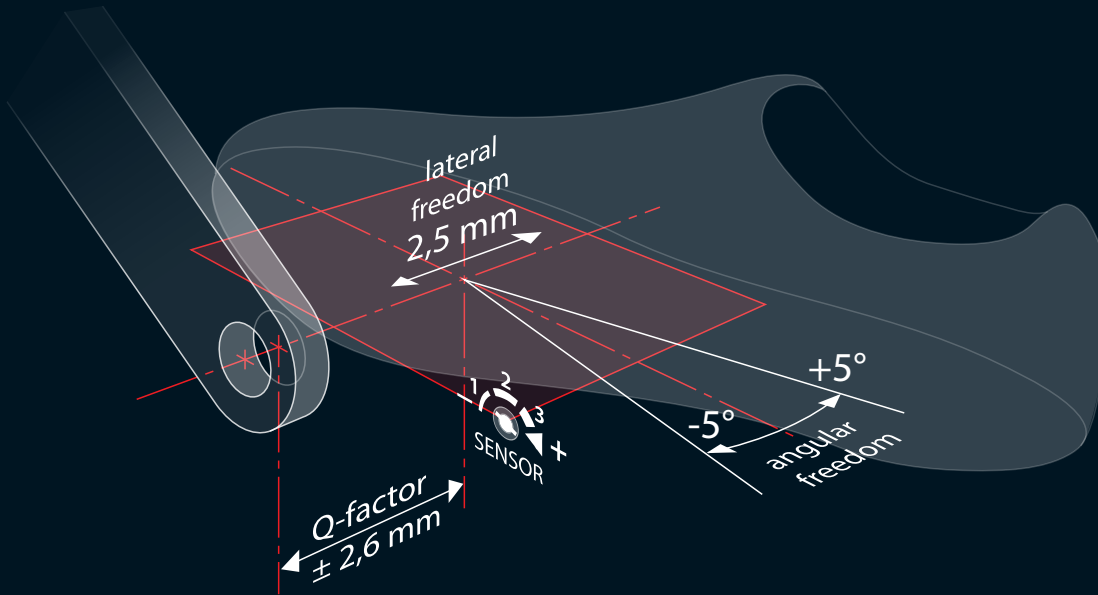

+ LIBERTÉ = + PERFORMANCE
+ FREEDOM = + PERFORMANCE

Seul le respect des appuis naturels, grâce à la précision des réglages et à la liberté des sensations permet de diminuer les risques de traumatismes articulaires et d'optimiser les performances suivant 3 points : sécurité, ergonomie et rendement.

Only by respecting the natural movements of your legs and joints, with angular and lateral float, as well as precise adjustment to the sensation or "feel" of the float, and with adjustable Q-factor Adjustment, can you decrease the risk of joint trauma and optimize performance following 3 points : security, ergonomics and performance.

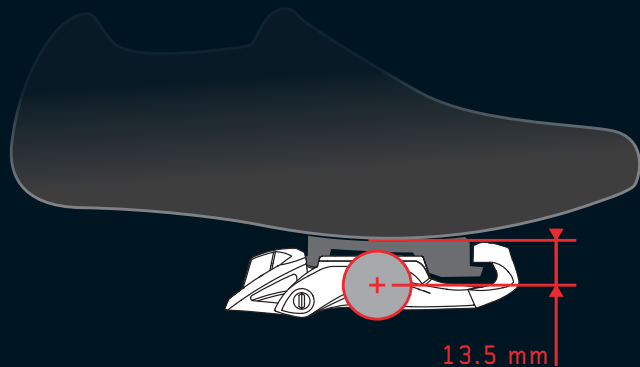

BioPosition minimale
minimal BioPosition

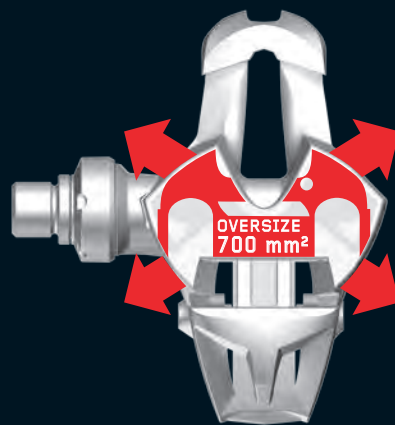

Large surface d'appui
Oversize pedal platform



Système Icllic
à pré-ouverture automatique (brevet TIME)
*Icllic System
with automatic pre-opening (TIME patent)*

Facilité et rapidité de chaussage
grâce à l'angle d'ouverture important
*Simple and speedy step-in
due to a vital step-in angle*

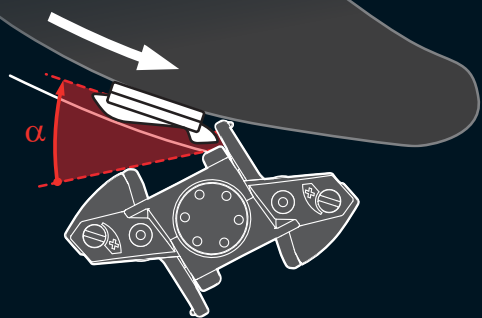

Concept «Self-Cleaning»
Chaque fois que vous chaussez la pédale TIME ATAC, la came vient chasser la boue ou le sable
*Each time you step into the TIME ATAC the lever
clears out any debris (mud, sand, etc...)*

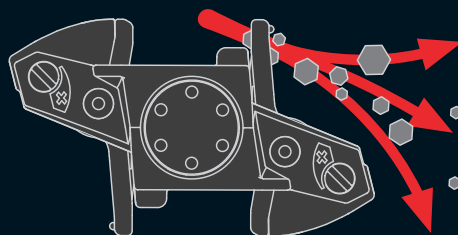

Choix de l'angle de déchaussage
Choice of release angle

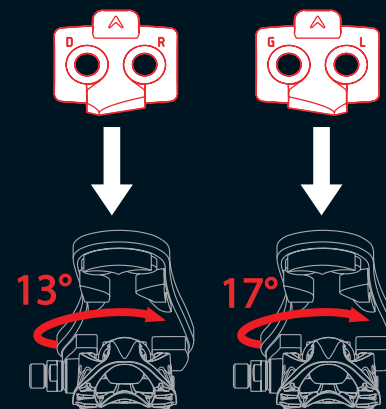

ROAD



Xpresso 15



Xpresso 12



Xpresso 10



Xpresso 8



Xpresso 6



Xpresso 6



Xpresso 4



Xpresso 2

p.38-39

ROAD



RXS Carbon



RXS Speed



RXS First

p.41

FABRIQUÉ EN FRANCE



X COUNTRY

ENDURO

DOWN HILL



ATAC XC12



ATAC XC8



ATAC XC6



ATAC XC6



ATAC XC4



ATAC XC2

p.44-45



ATAC MX12



ATAC MX8



ATAC MX6



ATAC MX6



ATAC MX4



ATAC MX2

p.48-49



ATAC DH4

p.51

FABRIQUÉ EN FRANCE





FAST LIGHT POWER TRANSMISSION

TIME révolutionne la technologie des pédales automatiques avec la nouvelle génération : Xpresso.

Le concept Icllic - pré-ouverture automatique (brevet TIME) - permet un enclenchement plus rapide, intuitif et sans effort. De plus, sa lame de flexion en carbone et sa zone d'appui oversize de 700 mm² lui confère un coefficient surface d'appui/poids record.

TIME has revolutionized clipless pedal technology and introduces its newest generation : Xpresso.

The Icllic concept - pre-open clipless system (TIME patent) - allows more intuitive engagement without any rubbing. Moreover, the carbon flexion blade and the oversize 700 mm² platform gives the pedal a record surface area/weight factor.

SPONSORED TEAMS

NERI SOTTOLI

VINI FANTINI NIPPO

ANDRONI GIOCATTOLI - VENEZUELA

COLOMBIA

XPRESSO



ROAD



XPRESSO 15
66,5g

Axe Titane creux / Hollow titanium axle
Roulements CERAMIC SPEED / CERAMIC SPEED bearings
Corps carbone light / Light carbon body
Capot aluminium / Aluminum plate

ceramicspeed

**JOHNNY
HOOGERLAND**
Netherland champion 2013

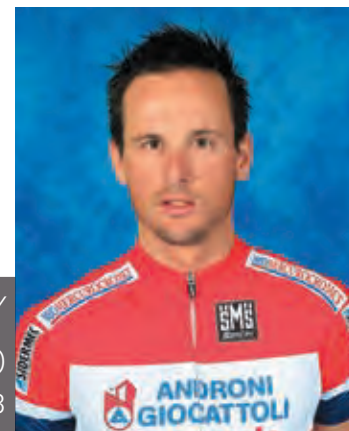



XPRESSO 12
77g

Axe Titane / *Titanium axle*
Corps carbone / *Carbon body*
Capot aluminium / *Aluminum plate*



XPRESSO 10
95g

Axe acier creux / *Hollow steel axle*
Corps carbone / *Carbon body*
Capot aluminium / *Aluminum plate*



XPRESSO 8
100g

Axe acier creux / *Hollow steel axle*
Corps composite / *Composite body*
Capot aluminium / *Aluminum plate*



XPRESSO 6
102g

Axe acier creux / *Hollow steel axle*
Corps composite / *Composite body*
Capot inox / *Stainless steel plate*



XPRESSO 4
112g

Axe acier / *Steel axle*
Corps composite / *Composite body*
Capot inox / *Stainless steel plate*



XPRESSO 2
112g

Axe acier / *Steel axle*
Corps composite / *Composite body*





**RXS
CARBON**
117g

Axe acier creux / *Hollow steel axle*
Corps carbone / *Carbon body*
Réglage des sensations / *Adjustment
of angular sensations*



**RXS
SPEED**
130g

Axe acier / *Steel axle*
Corps composite / *Composite body*
Réglage des sensations / *Adjustment
of angular sensations*



**RXS
FIRST**
130g

Axe acier / *Steel axle*
Corps composite / *Composite body*



ATAC XC

L'ALLIANCE DE LA TECHNOLOGIE ET DE LA FIABILITÉ
Le système ATAC combine une conception ultra light associée à une excellente évacuation de la boue et des impuretés grâce à son concept autonettoyant, pour une facilité de chaussage et une maîtrise du déchaussage. Les pédales de référence des plus grands champions.

*THE FUSION OF TECHNOLOGY AND RELIABILITY
The ATAC System combine an ultra light design with an exceptional mud and debris clearing system, thanks to its self-cleaning concept with an easy engagement and a mastered step-out.
It is the preferred pedals of the most elite champions.*



ATAC SYSTEM
LIGHT
RELIABLE



JULIE
BRESSET
OLYMPIC &
WORLD CHAMPION





ATAC XC12
124g

Axe Titane / Titanium axle
Corps carbone / Carbon body
Arceaux moulés / Stainless steel molded dual-arches
Réglage des sensations angulaires / Adjustment of angular sensations



ATAC XC8
143g

Axe acier creux / *Hollow steel axle*
Corps carbone / *Carbon body*
Arceaux moulés / *Stainless steel molded dual-arches*
Réglage des sensations angulaires / *Adjustment of angular sensations*



ATAC XC6
145g

Axe acier creux / *Hollow steel axle*
Corps composite / *Composite body*
Arceaux découpés / *Stainless steel stamped dual-arches*
Réglage des sensations angulaires / *Adjustment of angular sensations*



ATAC XC4
147g

Axe acier creux / *Hollow steel axle*
Corps composite / *Composite body*
Arceaux découpés / *Stainless steel stamped dual-arches*



ATAC XC2
151g

Axe acier / *Steel axle*
Corps composite / *Composite body*
Arceaux découpés / *Stainless steel stamped dual-arches*





ENDURO



© Julien Barety



ATAC MX12
158g

Axe Titane oversize / Oversized titanium axle
Corps carbone / Carbon body
Arceaux moulés / Stainless steel molded dual-arches
Axes ressorts creux / Hollow spring axle



ATAC MX8
182g

Axe acier creux oversize / Oversized hollow steel axle
Corps carbone / Carbon body
Axes ressorts creux / Hollow spring axle



ATAC MX6
190g

Axe acier creux oversize / Oversized hollow steel axle
Corps composite / Composite body
Axes ressorts creux / Hollow spring axle



ATAC MX4
192g

Axe acier creux / Hollow steel axle
Corps composite / Composite body



ATAC MX2
197g

Axe acier / Steel axle
Corps composite / Composite body





DH

ATAC DH4
258g

Axe acier creux oversize / Oversized hollow steel axle
Corps aluminium / Aluminium body
Réglage des sensations / Adjustment of angular sensations



FABRIQUÉ EN FRANCE







ERGODRIVE

Géométrie compact
full carbone RTM

Compact geometry
full carbon RTM

Ø 31.8mm

Renfort carbone localisé sous la potence / HM and HR fibers
with integrated carbon reinforcing sleeve

Passages de gaines intégrés avec cache amovible / Integrated
cable housing channels with removable ergonomic covers

3 tailles / Sizes : 42, 44, 46 cm

(extérieur-extérieur / outside-to-outside)

225 g



CINTRE PLAT FLATBAR

Ø 31.8mm

L = 700 mm

MONOLINK ULTEAM

Ø 31.8mm
Pivot/ Steerer Ø1" 1/8
5 longueurs / Lengths : 90, 100, 110, 120, 130mm
135 g



TRANSLINK
L = 110 mm



RETROFIT
L = 180 mm



STANDARD
L = 270 mm



3 longueurs / 3 lengths:

Translink

Retrofit

Standard

3 profils / 3 side faces:



Fluidity
Ø 31.6 mm



Izon



Skylon

TIGE DE SELLE SEATPOST

Conception RTM / RTM design

Pour montage interne électrique, commander le kit 55007941 pour le Skylon
For Di2/EPs internal set up, order kit 55007941 for SKYLON frame

Pour montage interne électrique, commander le kit 55007940 pour les autres modèles
For Di2/EPs internal set up, order kit 55007940 for other frame



CALES ICLIC
ICLIC CLEATS
85 g/paire



CALES RXS
RXS CLEATS
99 g/paire



CALES ATAC
ATAC CLEATS
45 g/paire



**5 CALES DE
COMPENSATION**
CLEAT WEDGES
LEG LENGTH KIT

Pour compenser une différence morphologique de longueur de jambes.
Fixation 3 trous standards
Épaisseur unitaire de 2 mm /
Compensates for anatomical difference in leg lengths
Mounted with 3 standard holes
Each wedge is 2 mm thick



**XPRESSO
BODY PLATE**

Versions aluminium (5 g) /
Aluminum version (5 g)
Versions acier inoxydable (7 g) /
Stainless steel version (7 g)



BIDONS
WATER BOTTLE
550ml

**PORTE-BIDON
CARBONE**
BOTTLE CAGE
CARBON

100 % carbone
25 g
2 finitions : mat - brillant /
Gloss finish - Matt finish



**GUIDOLINE
EVA LIEGE**
HANDLEBAR
TAPE EVA LIEGE

Noir ou blanc /
White or black



**HOUSSE À
CHAUSSURES**
SHOE BAG



HOUSSE À VÉLO
BIKE TRAVEL BAG

Compartiments roues /
Wheel compartments
L = 134 cm, h = 97 cm





ULTEAM MAX | 50% Coolmax®
+ 40% ClimaWell
S/M, L/XL



COOLMAX® | 90% Coolmax®
S/M, L/XL



AIR FLOW | Tissu Lycra®
S/M, L/XL

MEN



RACING | 8 Tailles / Sizes : 7 > 10,5



PERFORMANCE | Renforts silicone / Silicon pad
8 Tailles / Sizes : 7 > 10,5



COLORADO | Paume ultra résistante Pro Skin
Pro Skin ultra resistant palm
Renforts silicone / Silicon pad
8 Tailles / Sizes : 7 > 10,5

LADIES



STILETTO | Renforts silicone / Silicon pad
5 Tailles / Sizes : 6 > 8



STARLIGHT | Renforts silicone / Silicon pad
5 Tailles / Sizes : 6 > 8



Tom BOONEN



Greg LEMOND



Marco PANTANI



Gilbert DUCLOS LASSALE

TIME, A LEGENDARY PALMARES

Tour de France

87 LONGO
88 DELGADO
88 LONGO
89 LEMOND
89 LONGO
90 LEMOND
91 INDURAIN
92 INDURAIN
93 INDURAIN
94 INDURAIN
95 INDURAIN
97 ULLRICH
98 PANTANI

Giro

89 FIGNON
92 INDURAIN
93 INDURAIN
97 GOTTI
98 PANTANI
01 SIMONI
03 SIMONI
04 CUNEGO

Vuelta

89 DELGADO

Olympic Games

96 INDURAIN
96 LONGO
00 ULLRICH
00 MARTINEZ
04 BETTINI
04 ABSALON
08 ABSALON
12 BRESSET

World Championships

87 LONGO
88 LONGO
89 LEMOND
89 LONGO
91 TOMAC
94 GACHET
95 INDURAIN
95 LONGO
96 CHAUSSON
96 LONGO
97 BROCHARD
97 CHAUSSON
97 LONGO
98 DUPOUEY
98 CHAUSSON
99 ULLRICH
99 CHAUSSON
00 MARTINEZ
00 CHAUSSON
01 ULLRICH
01 LONGO
01 CHAUSSON
02 CHAUSSON
03 CHAUSSON
04 ABSALON
04 CHAUSSON
05 BOONEN
05 ROGERS
05 ABSALON
05 CHAUSSON
06 BETTINI
06 ABSALON
07 ABSALON
12 BRESSET
13 BRESSET

2 TOUR DES FLANDRES
3 PARIS ROUBAIX
4 MILAN SAN REMO
6 TOUR DE LOMBARDIE
6 AMSTEL GOLD RACE

BOONEN
DUCLOS LASSALE / BOONEN
POZZATO / FIGNON / BETTINI
MOTTET / DELION / BETTINI / CUNEGO
VAN DER POEL / VINOKOUROV / MAASSEN /
DI LUCA / ZABEL / CUNEGO
CASAGRANDE / AERTS / VERBRUGGHE /
ASTARLOA / DI LUCA

3 GAND WEVELGEM
3 LIEGE BASTOGNE LIEGE

GAUMONT / VANDENBROUCKE / BOONEN
VANDENBROUCKE / DI LUCA / VINOKOUROV

Plus de 100 étapes sur le Tour de France
More than 100 stages win on the Tour de France



Miguel INDURAIN

AUSTRALIA

TMO SPORTS PTY LTD
PO BOX 882 MASCOTT
NSW 200 MASCOT
TEL (61) 297 00 79 77
FAX (61) 297 00 79 11

AUSTRIA

KTM
KARLOCHNERSTRASSE 13
A-5230 MATTIGHOFEN
TEL (43) 77 424 09 192
FAX (43) 77 424 09 126

BENELUX

CODAGEX
ZANDBERGEN 10
B-2480 DESSEL – BELGIUM
TEL (32) 14 34 74 74
FAX (32) 14 32 39 04

CANADA

ARG SPORTS INC.
4566, AVENUE DE MELROSE
H4A 2S9 MONTREAL (QUEBEC)
TEL (1) 514 750 74 90

DENMARK

SCAN-BIKE
KNUDLUNDVEJ 5
DK-8653 THEM
TEL (45) 702 50 600
FAX (45) 702 50 699

FRANCE

TIME SPORT
2 AVENUE BLAISE PASCAL
38090 VAULX MILIEU
TEL (33) 04 74 99 95 89
FAX (33) 04 74 99 13 96

GERMANY

SHOCKER DISTRIBUTION
KELHEIMWINZERSTR. 101
93309 KELHEIM
TEL (49) 94 41 17 98 80
FAX (49) 94 41 17 98 81

MERIDA & CENTURION

RENNER KG
BLUMMENSTRASSE 51
D-71106 MAGSTADT
TEL (49) 71 59 94 59 44
FAX (49) 71 59 94 59 56

GREAT BRITAIN

EXTRA UK LTD
DATAMEX HOUSE
MORRIS CLOSE
PARK FARM INDUSTRIAL ESTATE
WELLINGBOROUGH
TEL (44) 19 33 67 21 70
FAX (44) 19 33 67 21 71

HONG KONG – CHINA

VIMTECH LTD
UNIT 801, TAI TAK INDL BLDG
2-12 KWAI FAT RD
KWAI CHUNG
HONG KONG
TEL (852) 2428 1100
FAX (852) 2791 1944

ITALY

DSB SRL
VIA DEL LAVORO 7
I-24030 OSIO OTTO
TEL (39) 035 482 42 73
FAX (39) 035 482 42 73

JAPAN

DINOSAUR INC.
2-8-15 KITANOSHONISHI-MACHI
NARA-SHI 630
TEL (81) 742 64 65 65
FAX (81) 742 64 65 56

KOREA

DAEJIN INTERNATIONAL
15 HYOSEONG-RO
NAM-GU, POHANG-SI
790-330 GYEONGSANGBUK-DO
KOREA SOUTH
TEL (82) 54 275 22 16
FAX (82) 54 275 22 17

NEW ZEALAND

BIKES INTERNATIONAL LTD
38 AIRPARK DRIVE
MANGERE 2022
AUCKLAND
TEL (64) 9 267 1245
FAX (64) 9 267 3032

MALAYSIA

SINAR PUNCAK SDN.BHD.
2440, LORONG PERUSAHAAN 10,
PRAI INDUSTRIAL ESTATE
13600 PRAI, PENANG
MALAYSIA
TEL (65) 4 397 0448
FAX (65) 4 399 1440

POLAND

FHU POREBA
30-499 KRAKOW
UL.KLUSZYNSKA 13
NIB944-134-07-41
POLAND
TEL (48) 12 264 90 24
FAX (48) 12 264 94 25

SPAIN

TIME SPORT ESPANA
ERIC SARTOR
TEL (34) 678 623 710
FAX (34) 93 755 30 63

SOUTH AFRICA

CYCLING J&J PTY LTD
169 MEERLUST ROAD
WILLOW GLEN
PRETORIA
SOUTH AFRICA
TEL (27) 12 807 5570
FAX (27) 12 807 4267

SWITZERLAND

LOUP CYCLING SA
CH-1587 MONTMAGNY
TEL (41) 26 67 72 226
FAX (41) 26 67 71 971

TAIWAN

LEE DUO TRADING CO LTD
15 F, NO. 80, SEC. 1
CHENGGONG RD,
YONGHE CITY
TAIPEI COUNTY 234
TAIWAN
TEL (866) 2 22 31 05 99
FAX (866) 2 22 31 46 83

THAILAND

UWC LIMITED
36/56/35-36 GREEN TOWER
11TH FLOOR
RAMA IV ROAD, KLONGTON
KLONGTOEY – BANGKOK
TEL (66) 23 673 470
FAX (66) 23 673 482

USA

TIME SPORT USA
5219 WEST 73RD STREET
MN-55439-2206 EDINA
TEL (1) 952 830 73 24

QUALITY BICYCLE PRODUCTS
6400 WEST 105TH STREET
BLOOMINGTON
MINNESOTA 55438 – 2554
TEL (1) 952 941 93 91
FAX (1) 952 656 52 62

FABRIQUÉ EN FRANCE

